

TRS 5

ME134554-00

Static Torque Sensor

Used either in torque display systems or in torque closed loop control systems, MEROBEL TRS series offer a plug-and-play solution for test rigs. When embedded in a closed loop system, it easily allows to dramatically increase the dynamic properties of a torque simulation device, and to build more accurate and stable regulation systems.



SPECIFICATIONS

Nominal Torque Range (FS)	Nm	5
Safe Load Limit	% FS	200
Supply (max)	V	5 (10)
Operating temperature	°C	0 - 80
Accuracy	% FS	± 0.2
Sensitivity	mV/V	0.5
Bridge resistance	Ω	350

BENEFITS

- ▶ Economical solution compared to dynamic torquemeter
- ▶ Compact & robust design
- ▶ High Torque measurement accuracy
- ▶ Design for direct fitting on MEROBEL FAT20 & FAT50
- ▶ Flexible wiring with 2m shielded cable
- ▶ Easy calibration solution with shunt resistor

DIMENSIONS

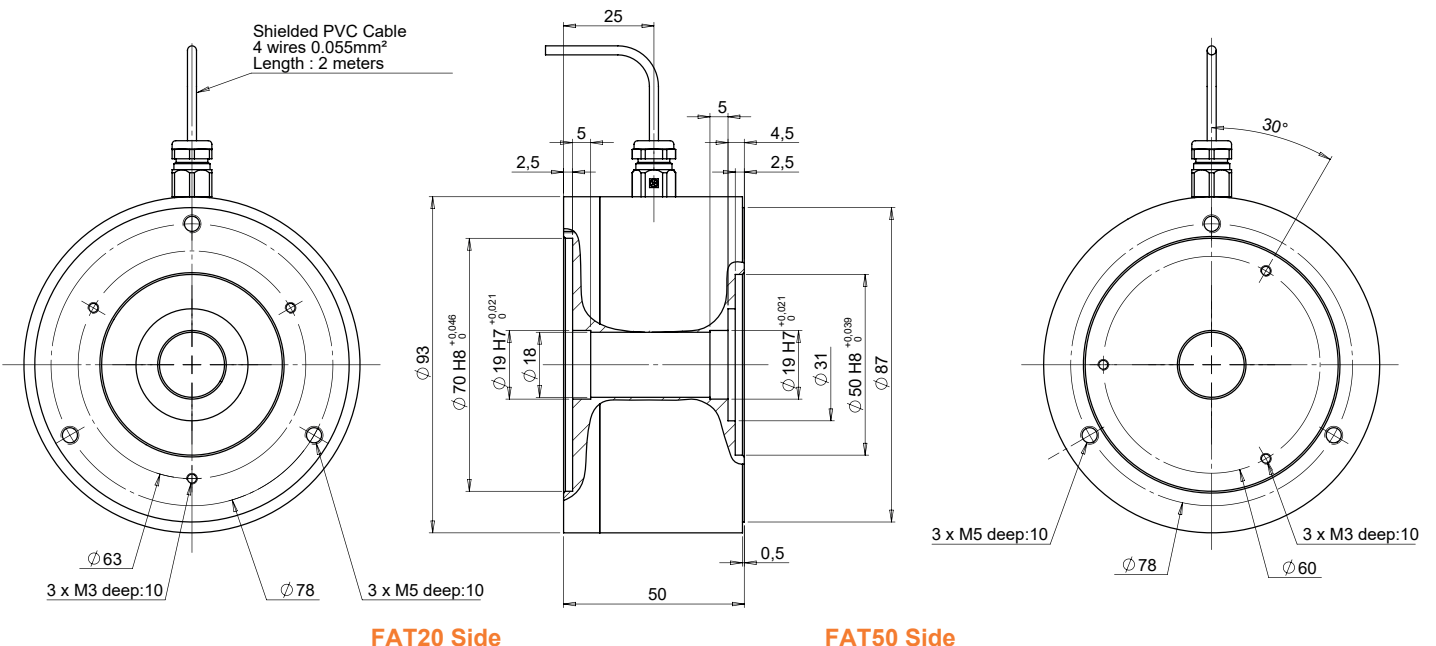

DIRECT MOUNTING CONFIGURATION

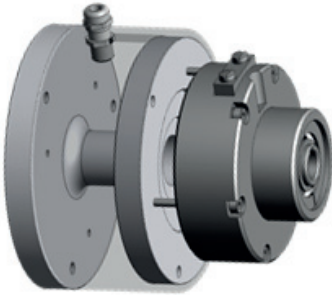

FAT20 Mounting

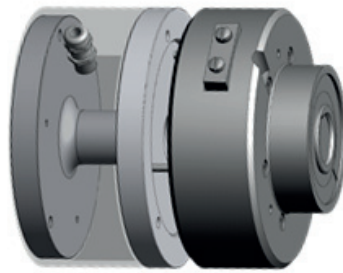

FAT50 Mounting

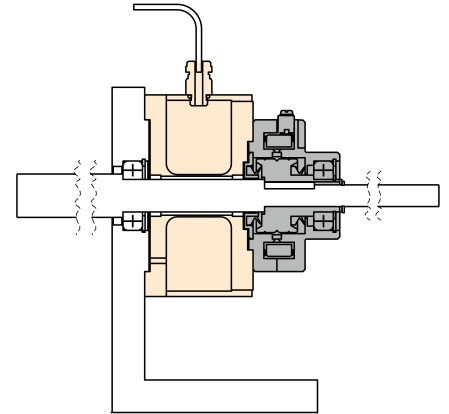

Assembly principle

WIRING

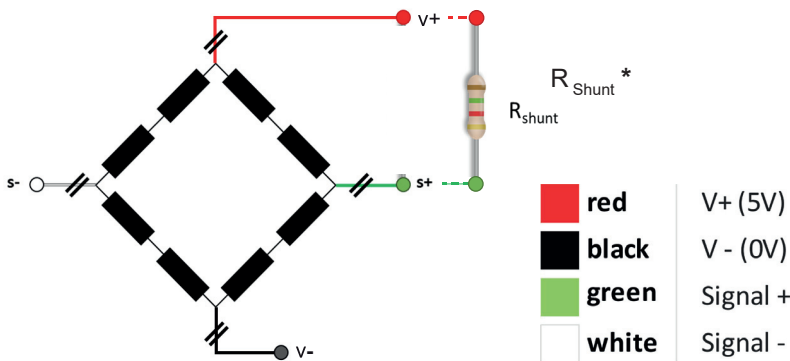

* Nota

- 1- Shunt resistor can be used for torque calibration simulation.
- 2- Torque equivalent value simulated by shunt is written on the product label.
- 3- Ask for dedicated documentation with MEROBEL controller DGT300+ or DGTBlock

APPLICATIONS Torque simulation for test Benches

CAN BE USED WITH :

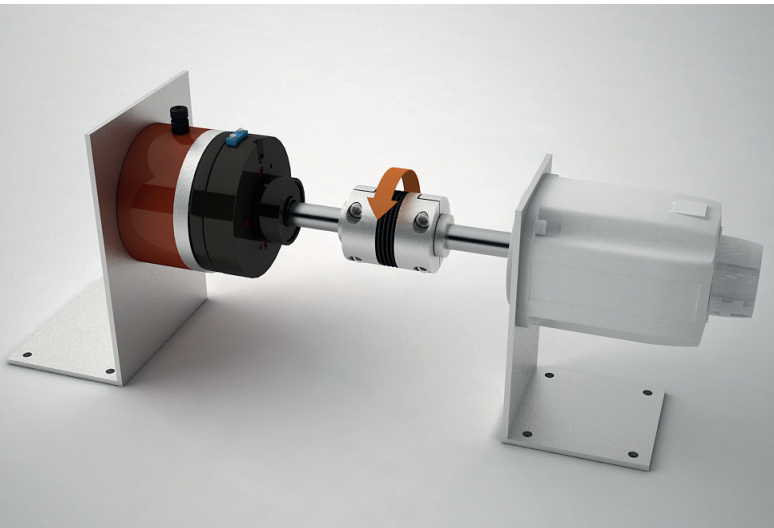

DGT300+
Closed loop
digital controller
HMI version



DGBlock
Closed loop
digital controller
Cabinet version