

2 FLANGE UNITS, METRIC SERIES

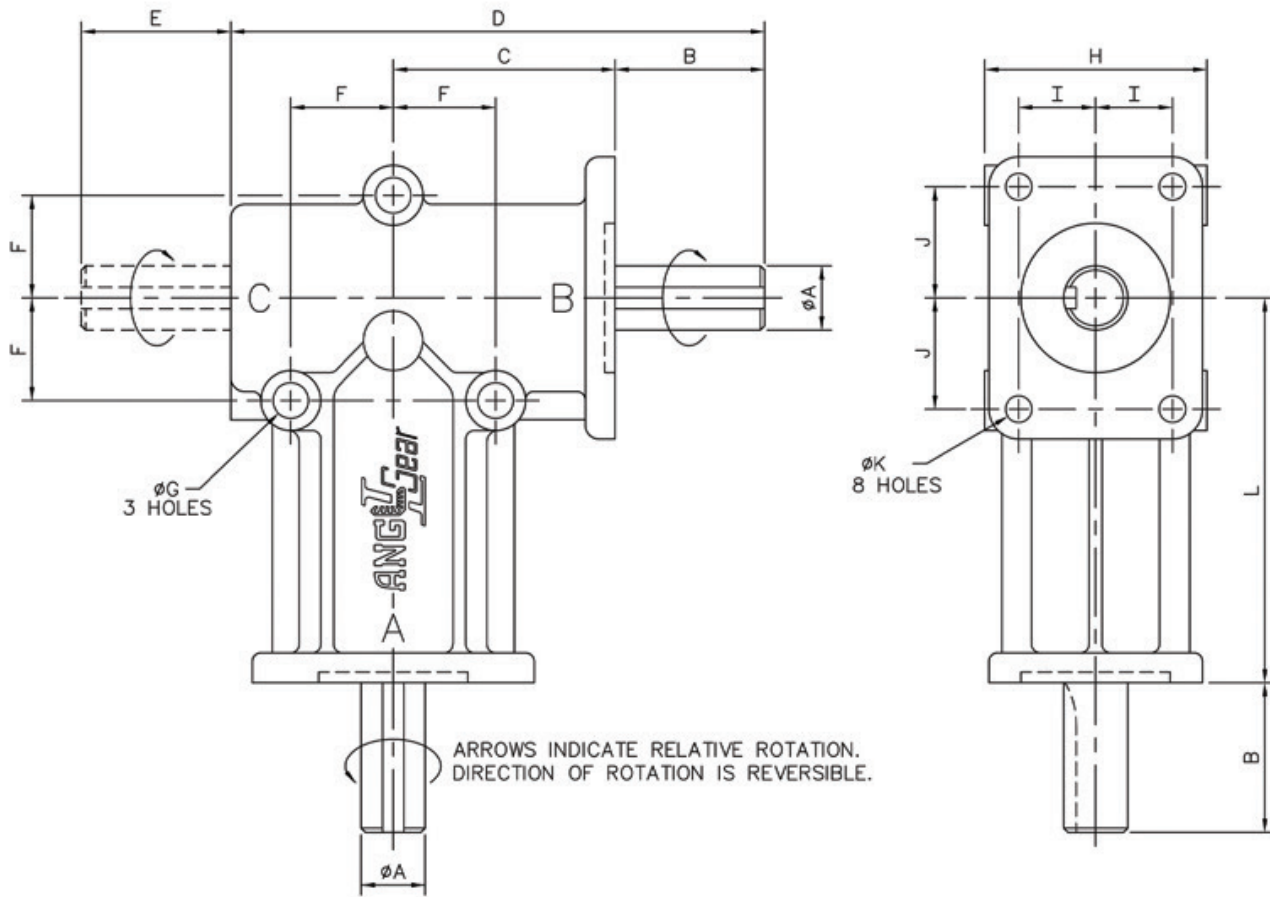

DIMENSIONS – 2 FLANGE UNITS *

Model	Type	A	B	C	D	E	F	G	H	I	J	K	L
R3000M/R3000-2M	2-Way	8	15	34	76	-	16	5.2	33	11	15	4.2	60
R3100M/R3100-2M	3-Way	8	15	34	76	15	16	5.2	33	11	15	4.2	60
R3200M/R3200-2M	2-Way	15	35	52	125	-	24	8.3	52	18	26	6.2	90
R3300M/R3300-2M	3-Way	15	35	52	125	35	24	8.3	52	18	26	6.2	90

Model numbers followed by "-2" indicates 2:1 reduction. 1:1 & 2:1 units have the same dimensions. Complete outline drawings are available upon request. Shaft diameter tolerances are ISO f7. All dimensions are in millimeters and are subject to change.

Keyway Dimensions: **SIZE 1 - R3000M / R3000-2M / R3100M / R3100-2M: None**
SIZE 2 - R3200M / R3200-2M / R3300M / R3300-2M: 3/16W x 3/32H x 1 1/2L

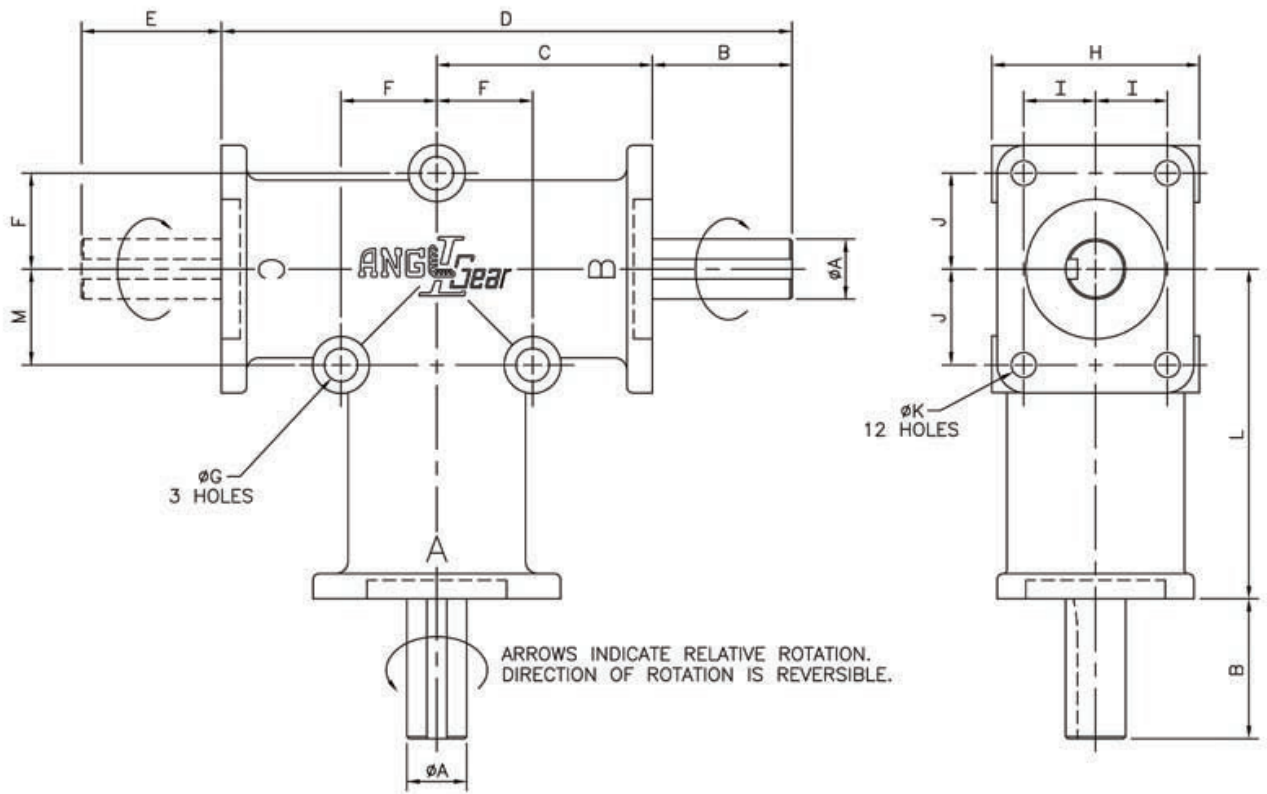

DIMENSIONS – 3 FLANGE UNITS *

Model	Type	A	B	C	D	E	F	G	H	I	J	K	L	M
R3003M/R3003-2M	2-Way	8	15	35	85	-	16.5	5.2	33	11	15	4.2	55	16.5
R3103M/R3103-2M	3-Way	8	15	35	85	15	16.5	5.2	33	11	15	4.2	55	16.5
R3203M/R3203-2M	2-Way	15	35	54	143	-	24	8.3	52	18	24	6.2	82.5	24
R3303M/R3303-2M	3-Way	15	35	54	143	35	24	8.3	52	18	24	6.2	82.5	24
R3330M/R3330-2M	2-Way	20	50	75	200	-	38	8.3	76	27	38	8.3	140	38
R3350M/R3350-2M	3-Way	20	50	75	200	50	38	8.3	76	27	38	8.3	140	38
R3400M/R3400-2M	2-Way	25	70	80	230	-	45	10.3	100	38	38	10.3	150	70
R3500M/R3500-2M	3-Way	25	70	80	230	70	45	10.3	100	38	38	10.3	150	70
R3600M/R3600-2M	2-Way	35	70	80	230	-	45	10.3	100	38	38	10.3	150	70
R3700M/R3700-2M	3-Way	35	70	80	230	70	45	10.3	100	38	38	10.3	150	70

Model numbers followed by "-2" indicates 2:1 reduction. 1:1 & 2:1 units have the same dimensions. Complete outline drawings are available upon request. Shaft diameter tolerances are ISO f7. All dimensions are in millimeters and are subject to change.

Keyway Dimensions: SIZE 1 – R3003M / R3003-2M / R3103M / R3103-2M: None
 SIZE 2 – R3203M / R3203-2M / R3303M / R3303-2M: 3/16W x 3/32H x 1 1/4L
 SIZE 3 – R3330M / R3330-2M / R3350M / R3350-2M: 3/16W x 3/32H x 1 1/4L
 SIZE 4 – R3400M / R3400-2M / R3500M / R3500-2M: 1/4W x 1/8H x 2L
 SIZE 5 – R3600M / R3600-2M / R3700M / R3700-2M: 1/4W x 1/8H x 2L

SELECTION & ORDERING INFORMATION, METRIC SERIES

Selection Procedure

- Determine the output speed and torque required for your application. The maximum recommended output speed is 3000 rpm for 1:1 units, and 1500 rpm for 2:1 units. 2:1 units are NOT recommended for use as speed increasers.
- Select an application service factor from the chart to the right. Multiply your torque by the selected service factor. If you are unsure of the factor to be used, please consult us.
- Using the chart below, find your output speed on the left. If your speed is not shown, use the next highest speed. Depending on the ratio you need (1:1 or 2:1), follow the chart across until you find a torque value that is larger than your corrected torque value.
- The Unit Size you need will be at the top of that column. There are 5 sizes available. At the bottom of the column is a list of the various models available under the selected size. Select the model number, based on the gear ratio and the number of shafts you need (2 or 3). When ordering, use the model number you selected, along with the ratio desired.
- Check the applied radial & thrust loads on the unit compared with the loads in the chart at the bottom. If the applied loads are larger than the chart values, a larger unit must be selected.
- Refer back to pages 4 & 5 for dimensional information on the model you selected.

SERVICE FACTORS

OPERATION CONDITIONS	UNIFORM LOAD	MODERATE SHOCK	
		3	1.3
SERVICE (hours/day)	8	1.3	1.4
	12	1.4	1.8
	24	1.8	2.5

$$T \text{ (Nm)} = 9,550 \times \text{kW} / \text{RPM}$$

$$\text{kW} = T \times \text{RPM} / 9,550$$

OUTPUT SPEED (RPM)	SIZE 1				SIZE 2				SIZE 3				SIZE 4				SIZE 5			
	Ratio 1:1		Ratio 2:1		Ratio 1:1		Ratio 2:1		Ratio 1:1		Ratio 2:1		Ratio 1:1		Ratio 2:1		Ratio 1:1		Ratio 2:1	
	T	kW	T	kW	T	kW	T	kW	T	kW	T	kW	T	kW	T	kW	T	kW	T	kW
50	4.70	0.02	1.25	0.01	16.60	0.09	5.02	0.03	50.5	0.26	27	0.14	89	0.47	39.1	0.20	132	0.69	72.2	0.38
100	4.20	0.04	1.09	0.01	14.50	0.15	4.65	0.05	44	0.46	26	0.27	79	0.83	37.4	0.39	118	1.24	67.7	0.71
200	3.70	0.08	0.96	0.02	12.60	0.26	4.42	0.09	38	0.80	24.5	0.51	69	1.45	36.1	0.76	102	2.14	63.3	1.33
300	3.40	0.11	0.91	0.03	11.60	0.36	4.20	0.13	34.7	1.09	23	0.72	62.9	1.98	34.9	1.10	93.2	2.93	61	1.92
400	3.20	0.13	0.86	0.04	10.90	0.46	3.97	0.17	32.5	1.36	22	0.92	58.7	2.46	33.2	1.39	86.9	3.64	56.6	2.37
500	3.07	0.16	0.84	0.04	10.45	0.55	3.86	0.20	31.1	1.63	21.5	1.13	55.9	2.93	32.3	1.69	82.7	4.33	55.1	2.88
750	2.79	0.22	0.77	0.06	9.70	0.76	3.64	0.29	28.7	2.25	20.3	1.59	50.2	3.94	30.2	2.37	74.1	5.82	50.4	3.96
1000	2.60	0.27	0.69	0.07	9.20	0.96	3.37	0.35	27.1	2.84	19	1.99	46.3	4.85	28.1	2.94	68.3	7.15	47.6	4.98
1250	2.48	0.32	0.65	0.09	8.83	1.16	3.20	0.42	26	3.40	18	2.36	43.5	5.69	26	3.40	64.1	8.39	44.1	5.77
1500	2.36	0.37	0.62	0.10	8.45	1.33	3.11	0.49	24.8	3.90	17.9	2.81	41.3	6.49	24.9	3.91	60.7	9.53	42.2	6.63
1750	2.25	0.41			8.00	1.47			23.7	4.34			39.3	7.20			57.4	10.5		
2000	2.18	0.46			7.90	1.65			22.8	4.77			37.9	7.94			55.5	11.6		
2500	2.06	0.54			7.80	2.04			21.3	5.58			35.3	9.24			51.6	13.5		
3000	1.95	0.61			7.70	2.42			20.2	6.35			33.3	10.5			48.6	15.3		

2-WAY	R3000M	R3000-2M	R3200M	R3200-2M	R3330M	R3330-2M	R3400M	R3400-2M	R3600M	R3600-2M
3-WAY	R3100M	R3100-2M	R3300M	R3300-2M	R3350M	R3350-2M	R3500M	R3500-2M	R3700M	R3700-2M
2-WAY	R3003M	R3003-2M	R3203M	R3203-2M						
3-WAY	R3103M	R3103-2M	R3303M	R3303-2M						

MODEL DATA (lbs)	R3000M		R3100M		R3200M		R3300M		R3330M		R3350M		R3400M		R3500M		R3600M		R3700M		
	1:1	2:1	1:1	2:1	1:1	2:1	1:1	2:1	1:1	2:1	1:1	2:1	1:1	2:1	1:1	2:1	1:1	2:1	1:1	2:1	
RADIAL LOAD	11.4	11.4	11.4	11.4	22.7	22.7	22.7	22.7	45.4	45.4	45.4	45.4	45.4	45.4	45.4	45.4	45.4	45.4	45.4	45.4	45.4
THURST LOAD	22.7	22.7	22.7	22.7	45.4	45.4	45.4	45.4	90.7	90.7	90.7	90.7	90.7	90.7	90.7	90.7	90.7	90.7	90.7	90.7	90.7
WEIGHT	0.23	0.23	0.23	0.23	1.00	1.00	1.09	1.09	3.95	3.95	4.08	4.08	6.58	6.58	6.80	6.80	7.94	7.94	8.16	8.16	8.16

* Unit ratings are: Output Torque in Nm and Output Power in kW.

Selection Example

An application to connect a drive-shaft to a fan-shaft at a right-angle with a 1:1 ratio. Input & output connections with timing belt pulleys at 1,000 rpm. Input power is 1 kW. Operating conditions are moderate shock, 12 hr/day.

- Output speed is 1000 rpm. Operating torque = $9,550 \times 1 \text{ kW} / 1000 \text{ rpm} = 9.55 \text{ Nm}$.
- Service factor from chart (12 hours/day, moderate shock) - SF=1.3. Corrected torque = $9.55 \times 1.3 = 12.42 \text{ Nm}$.
- From ratings chart (output speed = 1000 rpm), unit torque = 27.1 Nm (> 12.42 Nm) - Size 3 1:1.
- The model selected is: R3330M for two-way or R3350M for three-way.
- The applied radial loads are calculated to be 33.6 kg on each shaft (< 45.4 kg), which is allowable.
- On pages 7 & 8, the dimensions are checked to confirm available space for model selected.